

DEAN HOMICKI PTY LTD

CAPABILITY STATEMENT

—FEB 2022

SINCE
1987

DEAN
HOMICKI
PTY LTD

—FEB 2022

DEAN HOMICKI PTY LTD PROVIDES A DIVERSE & PRACTICAL COLLECTION OF CREATIVE SKILLS & BUSINESS EXPERTISE



DEAN HOMICKI —*Founder & CEO of
DEAN HOMICKI PTY LTD*

These valuable and strategic capabilities are what CEO Dean Homicki describes as entrepreneurial DNA, “They are building blocks, the processes, the ingredients to ‘connect the dots, that transport us from an idea to its actualisation.”

In this capability statement, you may identify with certain elements you have experienced. In contrast, others may be foreign, perhaps triggering the question, ‘Why is that required in my business for that product or service?’ Great, that’s how Dean Homicki Pty Ltd is different. No stone unturned, no step unknown & no surprises. Don’t you want to avoid costly mistakes, wasted time or relationships with partners & suppliers who do not share your vision or brand values?

The purpose of this capability list is to provide clarity & evidence of the attributes & actions required of an entrepreneur, business innovator or industry disruptor to obtain their goals and deliver the change they seek to make. These are known, practised and constantly developed cultural actives that we value.

In the past, you may have accessed Dean Homicki Pty Ltd to build you a website or e-learning series, develop a strategic marketing plan or a digital app, build a construction product or write twenty thousand words for a technical service manual? The really good news is that all Dean Homicki Pty Ltd clients have access to more than 30 years of hands-on knowledge and experience in building brands, creating remarkable products, & the sweet taste of return on investment.

We invite your comment and interaction, so please know that you are welcome to contact Dean Homicki for new ideas, new business & expertise in areas outlined in this capability statement.

DEAN HOMICKI
PTY LTD —SEP 2021

PRODUCT DESIGN & COMMERCIALISATION

DEAN
HOMICKI
PTY LTD

—FEB 2022

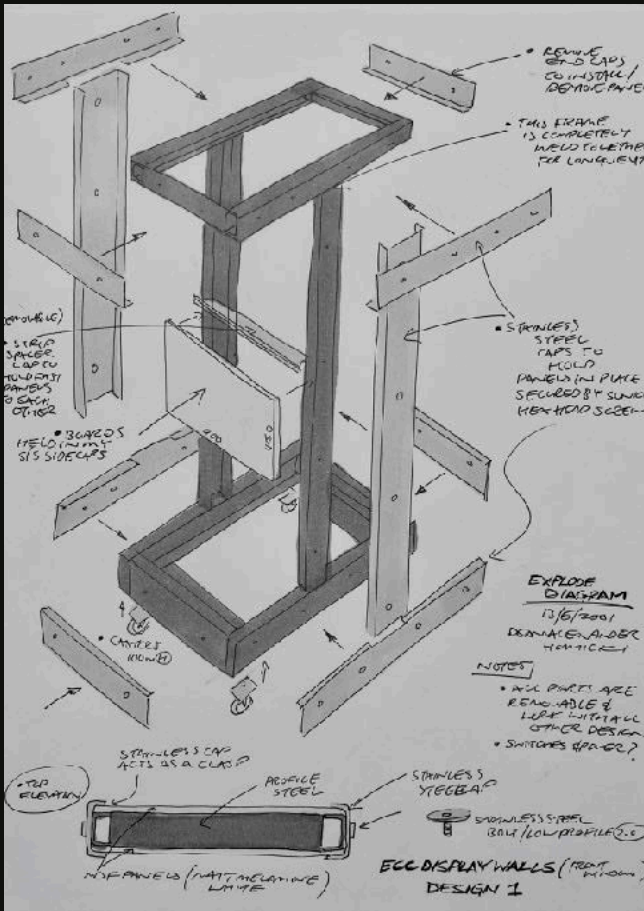

CAPABILITY

- market research & opportunity analysis
- product research & development
- product standards & compliance
- product design & manufacturing
- product modelling & prototyping
- product tooling & assembly design
- material sourcing & procurement
- product sampling & specification
- product performance & material testing
- product liability & risk analysis
- manufacturer sourcing & procurement
- manufacturing process design
- manufacturer product specification
- product identification & labelling
- product packaging & environment design
- product transport & shipping design
- product warranty & guarantee design
- product quality control & quality management
- product maintenance & repair
- product recovery design & refurbishment
- material design, reuse & recycling
- consumer product lifecycle design
- patents, trademarks & copyright
- IP licensing & selling
- IP agency agreements
- IP & product distribution agreements

—Hand drawn exploded diagram to explain the modular design for an electrical light moveable point of sale system design by Dean Homicki Pty Ltd & ECC Lighting showroom Melbourne

BRANDING & COMMUNICATION

DEAN
HOMICKI
PTY LTD

—FEB 2022

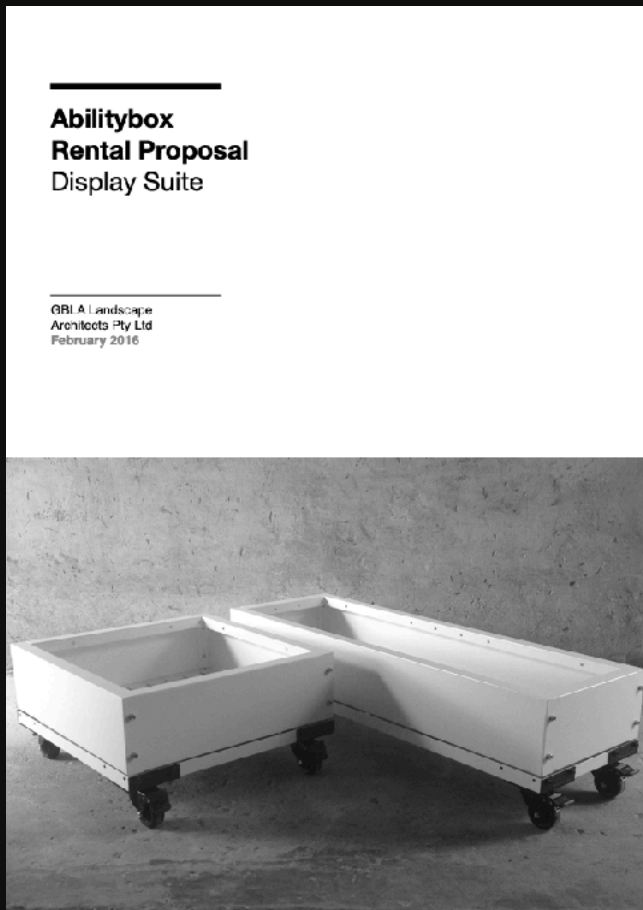

—Rental proposal & agreement drafted by Dean
Homicki Pty Ltd for ABILITYBOX garden systems

CAPABILITY

- brand values discovery & definition
- brand values phrasing & application
- brand service levels & situation design
- brand messaging & communication
- brand visual design & identity
- brand manuals & behaviour design
- brand names & tag lines
- brand messaging & client personas
- brand origin & storytelling
- brand value proposition
- brand copywriting & message
- brand white paper & contentions
- brand journal design
- brochure & sales document design
- digital & social media marketing
- email marketing & newsletters
- visual storytelling & storyboarding
- studio product photography
- application product photography
- product testimonial & filmography design
- filmography & visual brand messaging
- Video scripting & teleprompting
- video closed captioning & transcripts
- video post-production & editing
- video formatting, hosting & distribution
- audio recording & mastering
- audio scripting & narration
- audio podcasting & distribution
- product instructional diagram design
- product info & explainer graphics
- product exploded diagram design

MARKETING & SALES DESIGN

DEAN
HOMICKI
PTY LTD

—FEB 2022

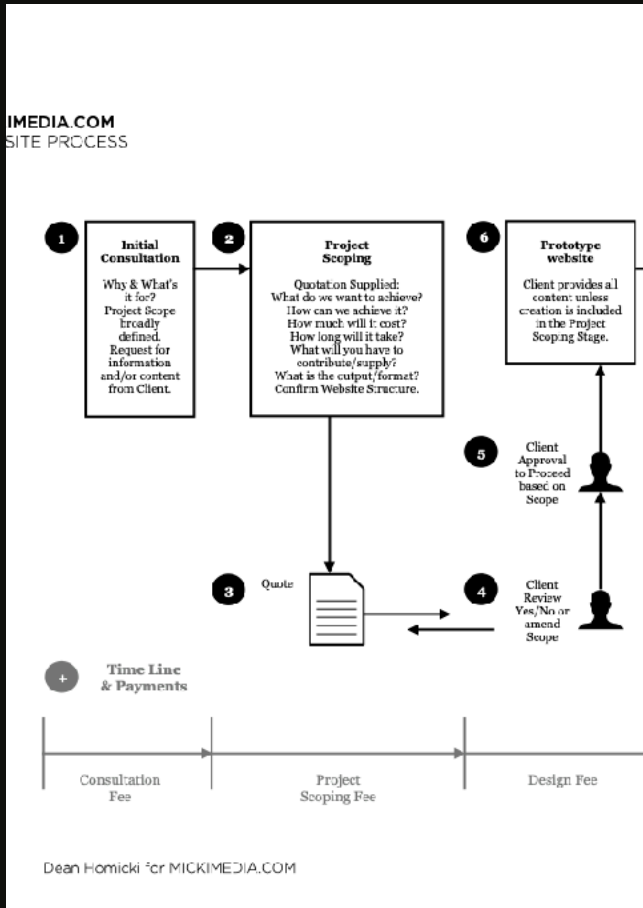

CAPABILITY

- customer journey & user experience design
- industry & market positioning design
- industry collaboration & partnerships
- sales & market strategy design
- sales process & activity design
- sales process tasks & measurements
- sales scripts & role-play design
- sales product training & application design
- sales & CRM system design
- digital database building & client acquisition
- communication & messaging automation
- product technical & specification design
- product sales tools & sampling design
- product service standards design
- product & environmental policy design
- website & digital application design
- online shopping & platform design
- b2B user awareness & education design
- b2C user purchase experience design
- retail systems & display design
- point of sale messaging & education
- b2B & b2C product packaging design

—Website development process & customer payment timeline for MICKIMEDIA business unit displayed as an infographic delivered in conjunction with the quotation/tendering process

PRODUCT KNOWLEDGE & TRAINING

DEAN
HOMICKI
PTY LTD

—FEB 2022

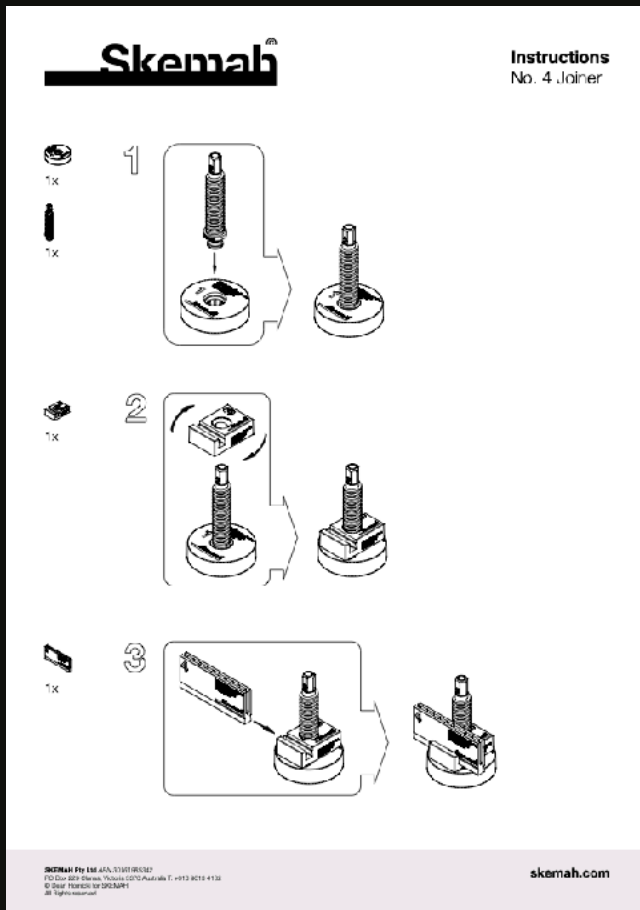

—Instructional diagram for assembly of a garden product system for SKEMAH for use as a part of the customer UX and online education process

CAPABILITY

- instructional design
- e-learning authoring & design
- product education design
- product induction training
- product application design
- product assembly design
- applicator training design
- applicator handbooks & manual design
- applicator quality checklist design
- consumer training design
- product & brand manuals
- product promotion & advertising design
- product workshop design
- product trade show & event design
- keynote presentation design
- business & brand values training
- business partners & industry education



—Online disability access app 'Mobility Access Design Library' for Stæbl Academy
—UX, graphic design and keynote slides and animations, CSS coding, content research, curriculum design, drone and film design and direction creation, audio and editing, closed captions and transcripts including WEB accessibility requirements and Membership integration

EXPERTISE & SPECIALISATION SUMMARY

DEAN
HOMICKI
PTY LTD

—FEB 2022

EXPERTISE

- Proven track record from product and service creation to return on investment (ROI)
- 30 years of experience building startups & creating products & services for emerging industries & markets
- International manufacturing, product development & supplier coordination in Asia (China mainland)
- Supply chain research, establishment & management
- Research, creation & establishment of new markets
- Manufacturing & construction expertise in method & systems including metal fabrication, polymers & adhesives, injection moulding & extrusions, casting, pressing, forming, forging, 3D printing, CNC turning and milling, surface finishes & treatments, handcrafted finishing techniques, printing, packaging, material selection, recycling, prototyping, testing & sampling
- Compliance & conformance experience with Standards, Regulations, business law, workplace & contractor law
- Producing, licensing & selling patents, trademarks & copyrighted designs, processes and materials, including applying for, defending & acting as an expert witness & litigation procedure
- 20 years experience in the roles of CEO, COO, CFO, CMO & CIO, directorships & board experience managing investors & banks, preparation & presentation of financial reporting, compliance & risk mitigation legal requirements
- Exited several businesses selling shares, assets & intellectual property to private owners

SPECIALISATION

- 30 years experience operating & partnering with businesses in the industries of architecture, construction, civil engineering, lighting, furniturer, signage hospitality, fashion, jewellery, marketing & communication
- Disability access design, education, compliance & conformance with niche products, installation & maintenance of TGSIs, stair edging, slip resistance & luminance contrast
- Designing & creating process-driven, people-centred, inclusive & profitable product & services businesses
- Education, training & knowledge transfer design of specialised subject matter of products and services. i.e. Instructional design, E-learning and content authoring and production



CLIENTS



DEAN
HOMICKI
PTY LTD

—FEB 2022



CLIENT CREATION

DIRECT & INDIRECT CLIENTS,
COLLABORATIONS, PROJECTS,
EVENTS, CONSULTANCIES,
PARTNERSHIPS, DISTRIBUTORS
AND RETAILER RELATIONSHIPS
MADE & NURTURED BY DEAN
HOMICKI SINCE 1992.



- 1994 —MYER
- 1995 —DAVID JONES
- 1998 —FAIRFAX-F.HANNAN P.
- 1998 —STA TRAVEL
- 1999 —NAB
- 1999 —TELSTRA
- 1999 —MIRVAC
- 2000 —MULTIPLEX
- 2001 —BATESSMART
- 2002 —MONASH HEALTH
- 2005 —CHANEL MELBOURNE
- 2006 —LOUIS VUITTON SYDNEY
- 2007 —ADEAS DUBAI METRO
- 2008 —RTA DUBAI UAE
- 2010 —La BIENNALE VENEZIA
- 2012 —BOISBUCHET FRANCE
- 2013 —VARIOUS PROJECTS



BRANDS BUILT

DEAN
HOMICKI
PTY LTD

—FEB 2022



DEAN
HOMICKI
PTY LTD



Skemah[®]



ABILITY BOX

BUSINESS CREATION

STARTUPS, BUSINESSES,
PROPRIETARY COMPANIES &
TRADING BRANDS, FOUNDED,
FUNDED & FULFILLED BY
DEAN HOMICKI SINCE 1987.



- 1987 —SMILESKATES
- 1990 —PAPPERSEASONS
- 1991 —YOBITS
- 1994 —ADORN
- 1995 —DAHDAH PTY LTD
- 1999 —D+
- 2000 —DTAC PTY LTD
- 2005 —INSAFE PTY LTD
- 2011 —DEAN HOMICKI PTY LTD
- 2012 —SKEMAH PTY LTD
- 2013 —ABILITYBOX
- 2014 —GARDEN COMMON
- 2015 —MICKIMEDIA
- 2016 —VINOWEELY
- 2017 —STÆBL
- 2020 —STÆBL ACADEMY



MICKI



VINOWEELY

INSAFE



RECOMMENDATIONS

DEAN HOMICKI PTY LTD

—FEB 2022

Sofiah Mackay
Senior Social Impact
Consultant at Think Impact
July 21, 2016,

Dean made a tremendous contribution to a session on business model development that I ran with 16 startup business entrepreneurs. As a guest speaker and seasoned business person, he brought incredible passion, insight and experience to the session that supported the group to think through their business models, testing their assumptions along the way. Drawing on well-earned experience, Dean shared invaluable tips around developing robust business models and the importance of crunching the numbers. He injected the session with invaluable enthusiasm, business know-how and positivity, all crucial to people in the early stages of developing a business. He left participants wanting more, and I certainly hope to have him back for other sessions as his contributions are succinct, pithy gold.

David Coward
Capital Project Portfolio Mngt.
August 5, 2015,

Dean is an inspiration to aspiring entrepreneurs. His designs and manufacturing techniques complement his range of products available to the marketplace. Dean takes on results-driven challenges, with the final product being of exceptional quality and outstanding value.

Michel Hogan
Brand Counsel, Writer and
Speaker
May 28, 2013,

Working with Dean to build the foundations for the Skemah organisation and brand reinforced the actual value of having a client who is an open collaborator willing to explore new ways of thinking and doing. Aside from having designed an excellent innovative garden design product, Dean brings his purpose and values into and across his whole endeavour.

Karin Knoester
Chief Executive Officer at Cystic
Fibrosis Community Care
May 27, 2013,

Dean and I worked in the same syndicate at the CEO Institute. During our sessions, I found Dean's analysis of situations to be insightful and thought-provoking. He is one of only a few people I know who is

genuinely connected to his purpose. He is an innovative and creative thinker who contributed significantly to the learnings of the group.

Geoff Gartly CA, CEPA
Managing Partner at Gartly
Advisory Chartered Accountants
September 13, 2012,

Dean has an irrepressible spirit and energy when it comes to design and innovation. Dean has risen to the challenge of developing the successful and innovative DTAC brand. I would recommend Dean to anybody considering entering a business relationship with him, as his level of commitment, loyalty and devotion to the task at hand is exemplary.

Murray Mountain
Director at Access Design
Solutions
June 28, 2012,

Dean is to be commended on the high standards for his company, staff, products and business dealings. He is also to be congratulated for his company in developing innovative products that benefit people with vision loss, all of which are used nationally and internationally to meet regulatory building requirements.

CONTACT & REFERANCES

DEAN HOMICKI PTY LTD

—FEB 2022

COMPANY NAME

DEAN HOMICKI
PTY LTD
ACN 152 168 655
ABN 53 152 168 655

ADDRESS

PO BOX 216
SOLDIERS HILL
BALLARAT VICTORIA
AUSTRALIA 3350

MOBILE

+61 413 516 333

EMAIL

hello@deanhomicki.design

WEBSITE

<https://deanhomicki.design>

SKYPE

dean.homicki

LINKEDIN

[https://www.linkedin.com/in/
deanhomicki/](https://www.linkedin.com/in/deanhomicki/)

VIDEO CHANNELS

—DEAN HOMICKI

<https://www.youtube.com/channel/UCh5zx4UDlhtiDrXYQJrJHzQ>

—STÆBL ACADEMY

<https://www.youtube.com/channel/UChE4hy6rqWR4oCUDaR64U8Q>

—VINOWEELY

<https://www.youtube.com/channel/UC-gNoatsCcC4Lcxa9QZvSmw>

—GARDEN COMMON

<https://vimeo.com/showcase/8244636>

—SKEMAH

<https://vimeo.com/showcase/8793337>

—ABILITYBOX

<https://vimeo.com/showcase/8793348>

—MICKI

<https://vimeo.com/showcase/8800130>

SOCIALS

—INSTAGRAM

<https://www.instagram.com/deanhomicki>

—LINKEDIN

<https://au.linkedin.com/in/deanhomicki>

TWITTER

—<https://twitter.com/deanhomicki>